

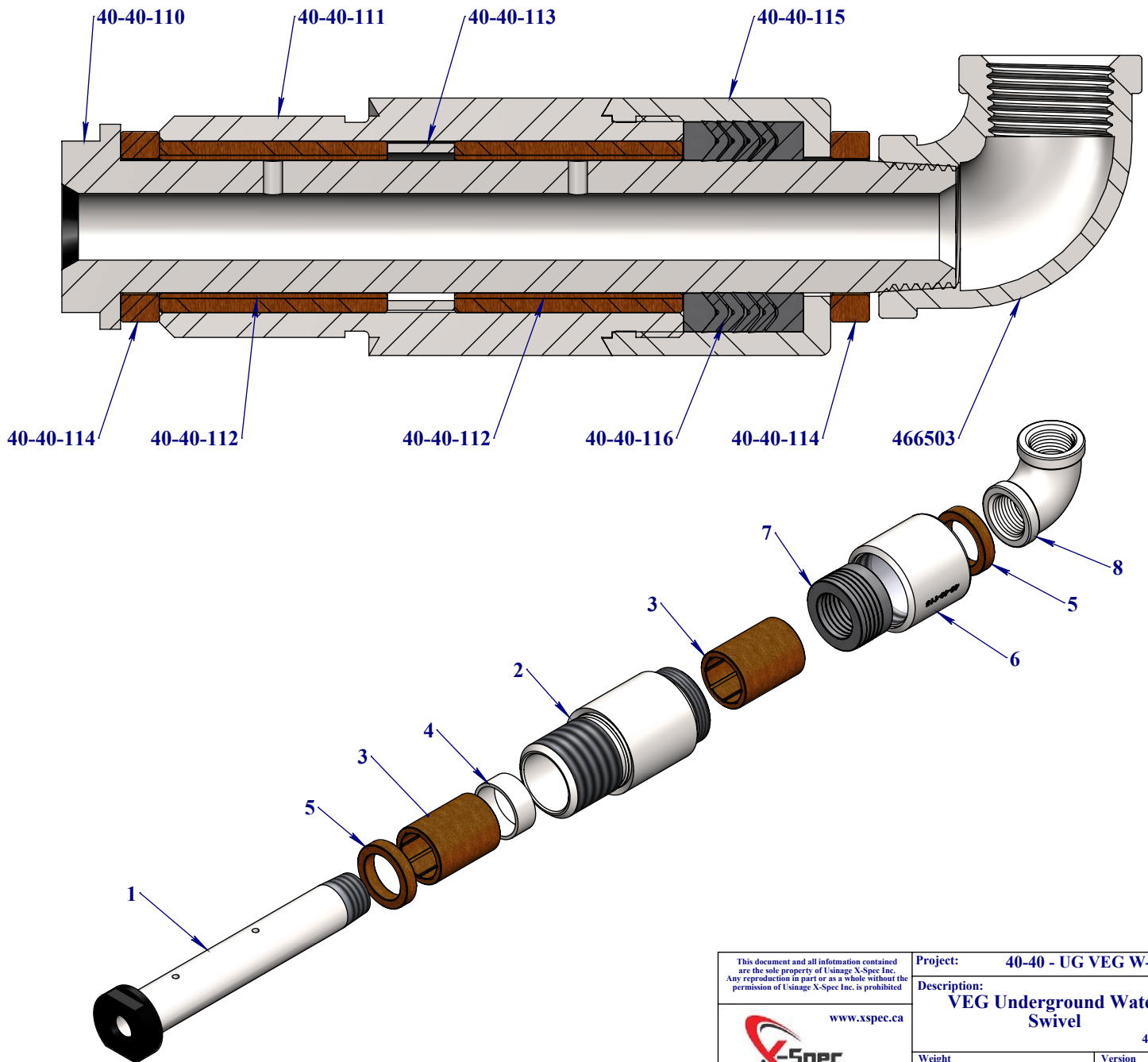

Item #	Part #	Description	Atlas Copco #	Unit Weight
1-8	40-40-100	VEG Underground Water Swivel	3002509	2.409

Item #	Part #	Description	Atlas Copco #	Qty	Unit Weight
1	40-40-110	Spindle	3002136	1	0.805
2	40-40-111	Swivel Body	3002138	1	0.878
3	40-40-112	Spindle Bushing	1031046	2	0.028
4	40-40-113	Spacer	3002139	1	0.026
5	40-40-114	Thrust Washer	3002137	2	0.007
6	40-40-115	Gland Nut	3002140	1	0.350
7	40-40-116	V-Packing	5042003	1	0.023
8	466503	1/2 NPT 90° 150 lb Galvanized Malleable Iron Pipe Elbow	3002168	1	0.26



<small>This document and all information contained are the sole property of Usage X-Spec Inc. Any reproduction in part or as a whole without the permission of Usage X-Spec Inc. is prohibited</small> www.xspec.ca 	Project: 40-40 - UG VEG W-S	
	Description: VEG Underground Water Swivel	
	Weight: 2.409 lbs	Version: 2019-05-08
	Filename: A3314.slddrw	