

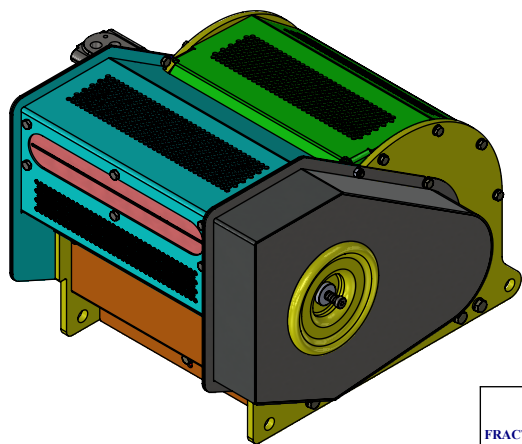

Infos Mat. Prem / Raw Mat. Info	
Internal P/N	C3839
Catalog P/N	206-200

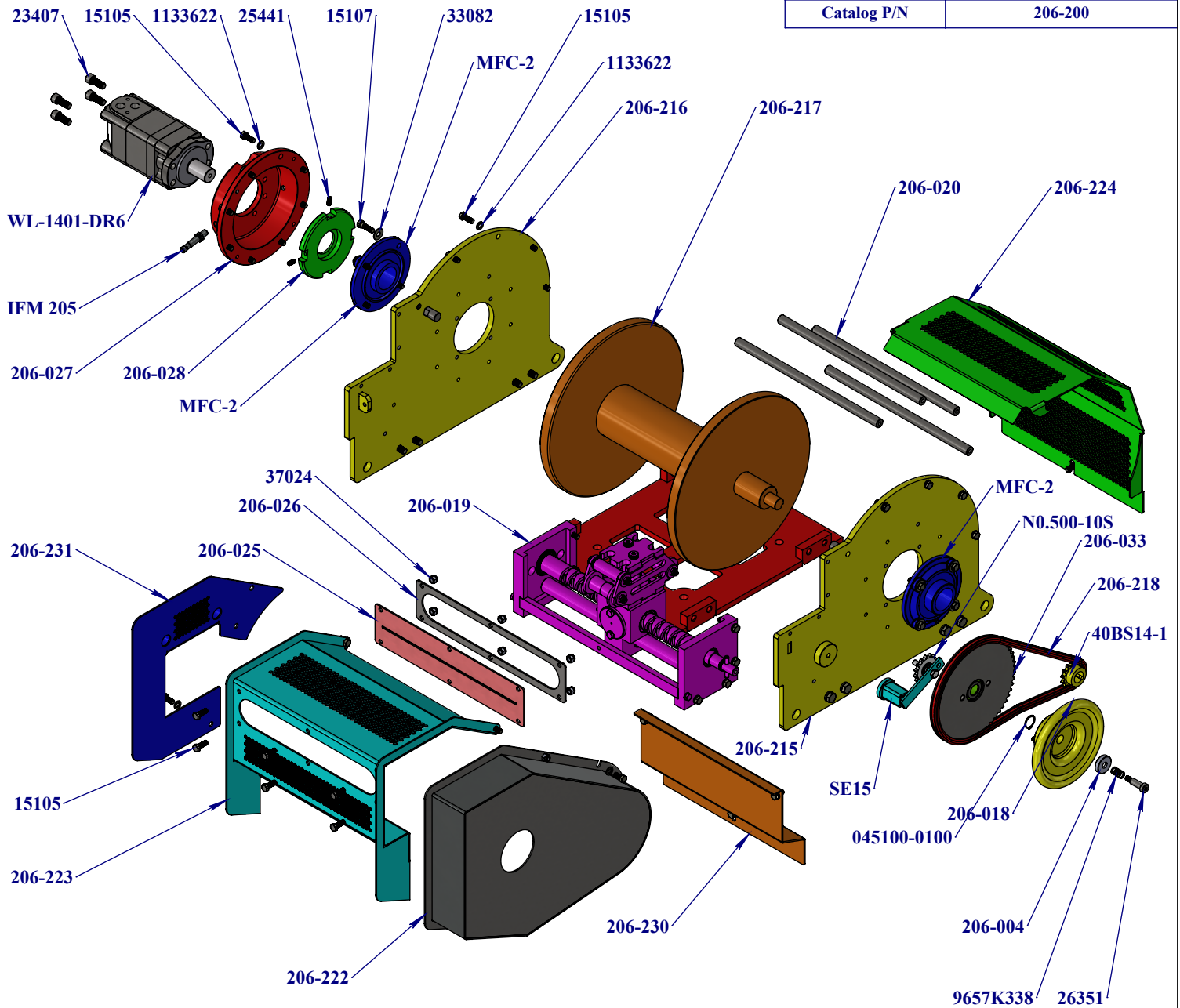

SI NON SPÉCIFIÉ LES DIMENSIONS SONT EN POUCES ET LES TOLERANCES: FRACTIONS DECIMALES ANGLES $\pm 1/16"$.XX ± 0.05 $\pm 1\text{deg}$.XXX ± 0.005		CE DOCUMENT ET TOUTES LES INFORMATIONS QU'IL CONTIENT SONT LE PROPRIÉTÉ DE USINAGE X-SPEC INC. TOUTE REPRODUCTION EN TOTALITÉ OU PARTIELLE EST INTERDITE SANS L'AUTORISATION DE USINAGE X-SPEC INC.		PROJET: 206-200 - Hoist XW-1300	
DESSINÉ PAR: System Administrator Poids/Weight 426.61 lbs		2023-11-28		DESCRIPTION: Wireline Hoist, 1300m Capacity (0.188 Wireline cable), XW1300	
		ÉCHELLE: 1:12		206-200 # DE DESSIN: C3839 REV. A NOM DU FICHIER: C8354.slddrw FEUILLE 1 DE 2	
www.xspec.ca					

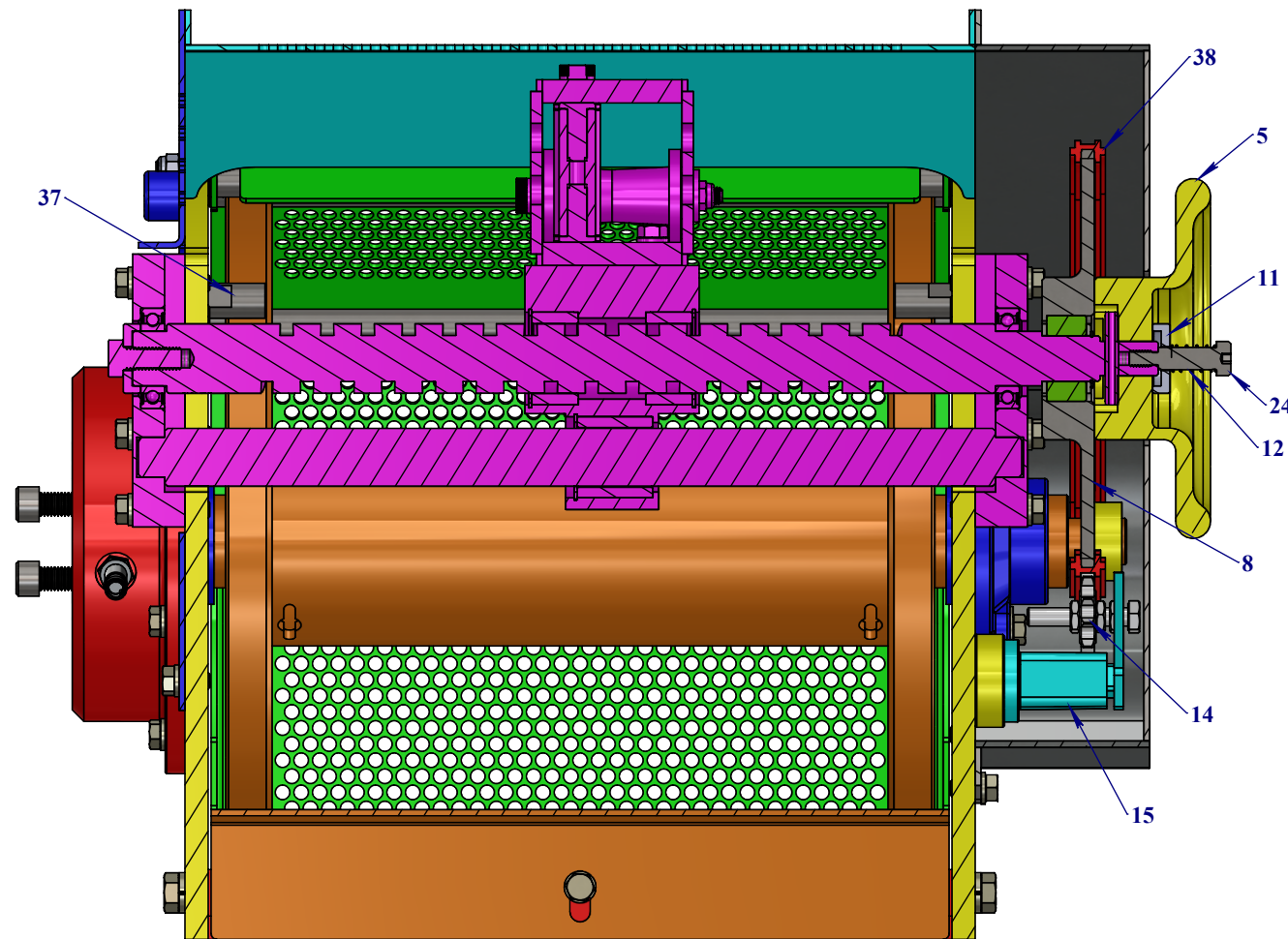
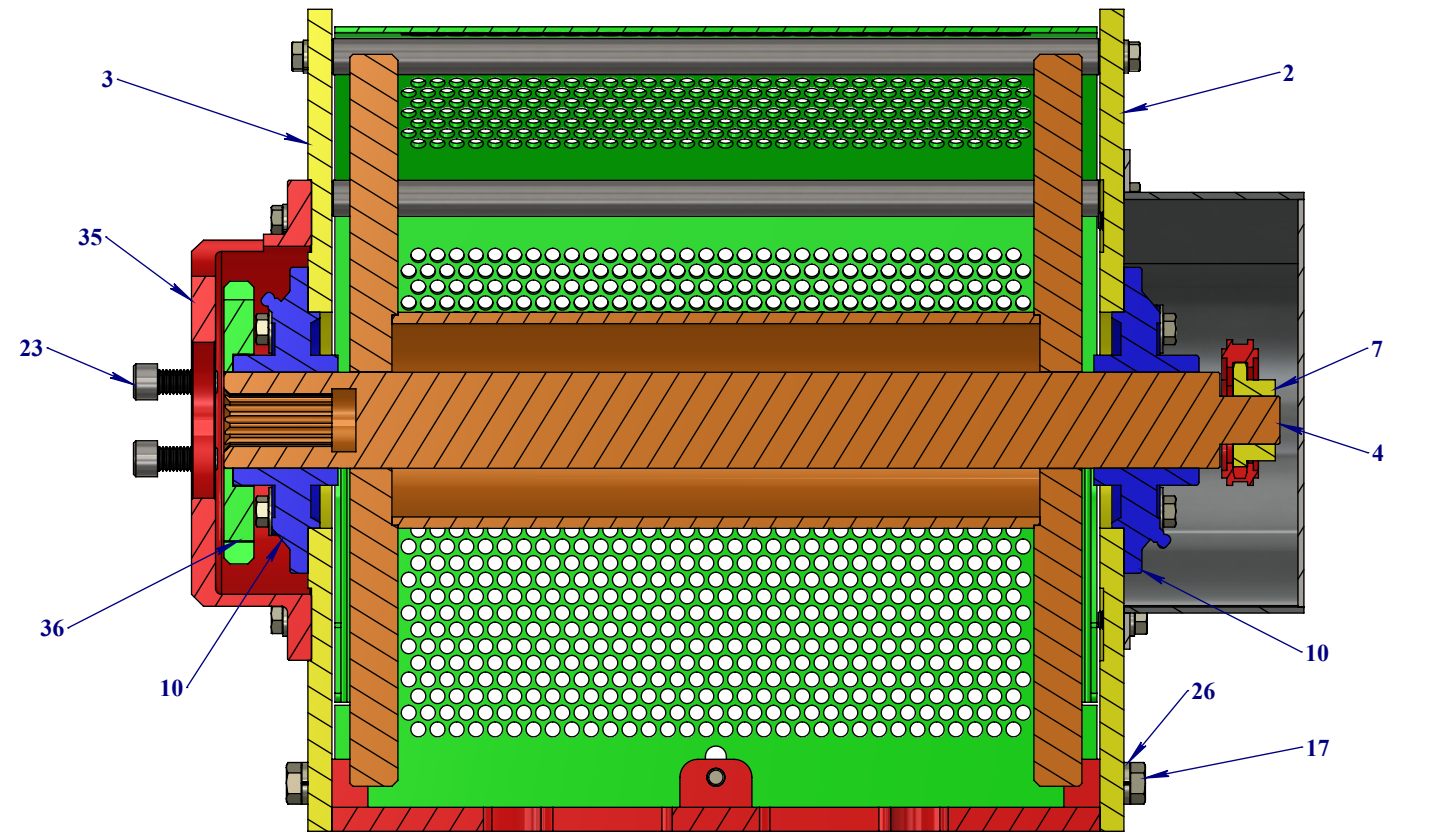

Item #	Part Number	Description	Qty	Unit Weight
1	206-214	Assemblage Fond Hoist X1300	1	35.586
2	206-215	XW1300 Right Side Plate	1	42.321
3	206-216	XW1300 Winch Left Side Plate	1	41.779
4	206-217	Drum Hoist X1300	1	129.997
5	206-018	Handle Assy	1	8.92
6	206-019	Winding Screw Assy	1	56.869
7	40BS14-1	40BS14 Sprocket, Bore 1.000"	1	0.46
8	206-033	Sprocket, C/W Bushing	1	6.486
9	206-020	Shaft	4	1.97
10	MFC-2	Cast Iron Flange Cartridge Bearing Unit, 2.000"	2	6.168
11	206-004	Washer	1	0.116
12	9657K338	Compression Spring	1	0.005
13	045100-0100	External Retaining Ring	1	0.0037
14	N0.500-10S	Tensioner Sprocket Assy	1	0.368
15	SE15	Rosta Tensioner	1	0.000000
16	15105	3/8-16 x 1" Grade 8 Yellow Zinc Finish Hex Cap Screw	22	0.0454
17	15207	1/2-13 x 1-1/4" Grade 8 Yellow Zinc Finish Hex Cap Screw	8	0.1037
18	15103	3/8-16 x 3/4" Grade 8 Yellow Zinc Finish Hex Cap Screw	12	0.0406
19	33082	3/8" x 0.812" OD Low Carbon Zinc Finish Steel SAE General Purpose Flat Washer	8	0.012
20	15107	3/8-16 x 1-1/4" Grade 8 Yellow Zinc Finish Hex Cap Screw	8	0.0547
21	37024	3/8-16 Grade 2 Zinc Finish NE Steel Nylon Insert Lock Nut	8	0.022
22	15110	3/8-16 x 1-3/4" Grade 8 Yellow Zinc Finish Hex Cap Screw	8	0.0704
23	23407	1/2-13 x 1-1/4" ASTM A574 Hex Drive Black Oxide Finish Alloy Steel Socket Cap Screw	4	0.102000
24	26351	1/2 Shoulder x 1-1/4" Shoulder Length x 3/8-16 Black Oxide Alloy Steel Socket Shoulder Bolt	1	0.120
25	1133622	3/8 Zinc Finish Medium Split Lock Washer	33	0.006
26	1133626	1/2 Zinc Finish Medium Split Lock Washer	8	0.013
27	25441	5/16-18 x 3/4" Hex Drive Cup Point Black Oxide Finish Alloy Steel Socket Set Screw	2	0.012
28	206-222	Hoist X1300 Guard	1	17.830
29	206-223	Front Guard Assy	1	15.088
30	206-231	Left Guard	1	4.707
31	206-224	Drum Guard	1	11.950
32	206-025	Liner, 0.250"	1	0.268
33	206-026	Holding Plate	1	0.870
34	206-230	Guard Plate	1	6.202
35	206-027	Motor Mount	1	12.498
36	206-028	Encoder Ring	1	3.674
37	206-029	Shaft	2	0.13
38	206-218	Drive Chain, Wireline Hoist, 42" OAL	1	2.886

SI NON SPÉCIFIÉ LES DIMENSIONS SONT EN POUCES ET LES TOLÉRANCES: FRACTIONS DÉCIMALES ANGLES $\pm 1/16"$ $.XX \pm 0.05$ $\pm 1 \text{deg}$ $.XXX \pm 0.005$	CE DOCUMENT ET TOUTES LES INFORMATIONS QU'IL CONTIENT SONT LA PROPRIÉTÉ DE USINAGE X-SPEC INC. TOUTE REPRODUCTION EN TOTALITÉ OU PARTIELLE EST INTERDITE SANS L'AUTORISATION DE USINAGE X-SPEC INC.	PROJET: 206-200 - Hoist XW-1300 DESCRIPTION: Wireline Hoist, 1300m Capacity (0.188 Wireline cable), XW1300
	DESSINÉ PAR: System Administrator 2023-11-28 Poids/Weight: 426.61 lbs	SIZE B: C3839 # DE DESSIN: C3839 NOM DU FICHER: C8354.stddrw

